

THIS DRAWING IS UNPUBLISHED. RELEASED FOR PUBLICATION, 19 .
 © COPYRIGHT 19 BY AMP INCORPORATED. ALL INTERNATIONAL RIGHTS RESERVED.

LOC	DIST	P	F	REVISIONS			
ZONE	LTR	DESCRIPTION	DATE	APPD			
G	14			B	REVISED & REDRAWN PER 0720-0044-94	4/28/94	OKS DAP

METRIC
 DIMENSIONS LISTED IN mm [INCHES]

AMP WIRE RANGE	E13288 Listed
12-10 AWG SOLID OR STRANDED	NOT APPROVED
LR7189 Certified	MILITARY P/N AND CLASS
12-10 AWG SOLID OR STRANDED	NOT APPLICABLE

SERRATIONS
 BRAZED SEAM

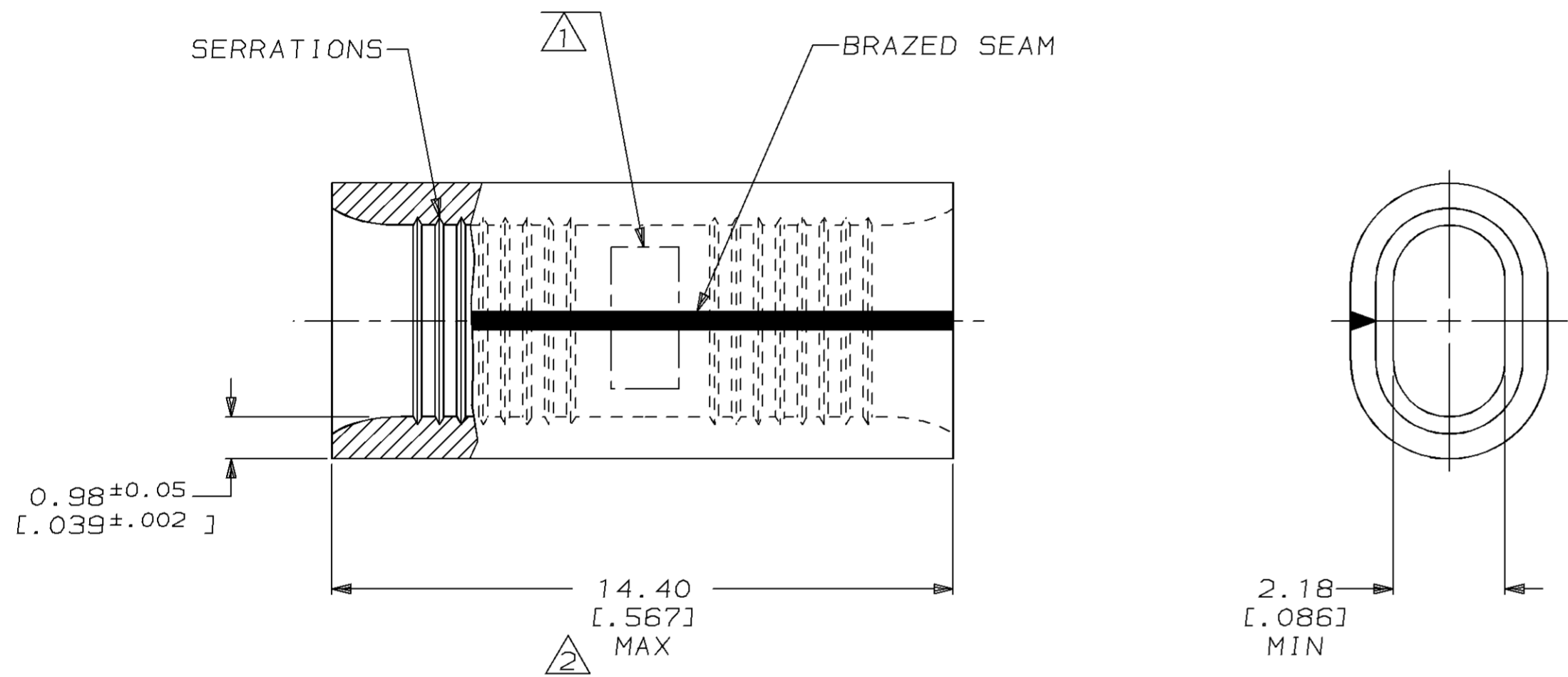

- 1 STAMP AMP 12-10 APPROX AS SHOWN
- 2 MAXIMUM LENGTH DOES NOT INCLUDE MANUFACTURING TABS

AMP INCORPORATED CUSTOMER SERVICE SYSTEMS		MAX RECOMMENDED OPERATING TEMPERATURE: 170°C MAX	DO NOT SCALE PRINT. UNLESS SPECIFIED DIMENSIONS IN mm [INCHES] TOLERANCES ON : 2 PLC DEC ± - 3 PLC DEC ± - ANGLES ± -	DR 4/28/94 DK SCHRUM CHK 5/5/94 DA PATTERSON APPD 5/5/94 CH KULYNYCH APPD 5/5/94 JL MECKLEY PRODUCT SPEC - APPLICATION SPEC - WEIGHT -	51893 PART NO
		VOLTAGE RATING: NOT APPLICABLE	MATERIAL COPPER PER ASTM B-152 ANNEALED	FINISH TIN PLATE 0.00254 [0.00100] MIN THK PER MIL-T-10727	AMP Incorporated Harrisburg, PA 17105-3608
FOR ADDITIONAL PRODUCT INFORMATION OR COPIES OF DRAWINGS AND TECHNICAL DOCUMENTS	PRODUCT INFORMATION CENTER 1-800-522-6752	WIRE CROSS SECTIONAL AREA RANGE: 2.62-6.64mm² [5,180-13,100] CIR MILS SOLID OR STRANDED	NAME SPLICE, BUTT, STANDARD, OVALED, SOLISTRAND™	SIZE C 00779	DRAWING NO C=51893
FOR APPLICATION TOOLING INFORMATION	TOOLING ASSISTANCE CENTER 1-800-722-1111	THIS DRAWING IS A CONTROLLED DOCUMENT FOR AMP INCORPORATED. IT IS SUBJECT TO CHANGE AND THE CONTROLLING ENGINEERING ORGANIZATION SHOULD BE CONTACTED FOR THE LATEST REVISION.	SCALE 8:1	SHEET 1 OF 1	CUSTOMER DRAWING
FOR ORDER ENTRY 1-800-526-5142					